

## TACT Switch™ Side Push Type

NEW  
2014

SKTD Series

Surface mount type realizing an excellent operating feel and a long life (IP67-rated)



### Features

- Height of only 1.55mm above the PCB contributes to smaller, thinner devices
- Soldering of the frame realizes outstanding strength when mounted
- Sealed contact structure ensures a highly reliable switch (IP67 dust and water resistance)

### Applications

- Smartphones, other mobile devices, cameras and wearable electronics

### Typical Specifications

Dimensions	3.9 x 2.9 mm (Installed height: 1.55 mm)
Operating force	1.6 N
Travel	0.15 mm
Operating life	200,000 cycles
Maximum rating	12V DC50mA
Initial contact resistance	500mΩ max.

### Dimensions

Unit:mm

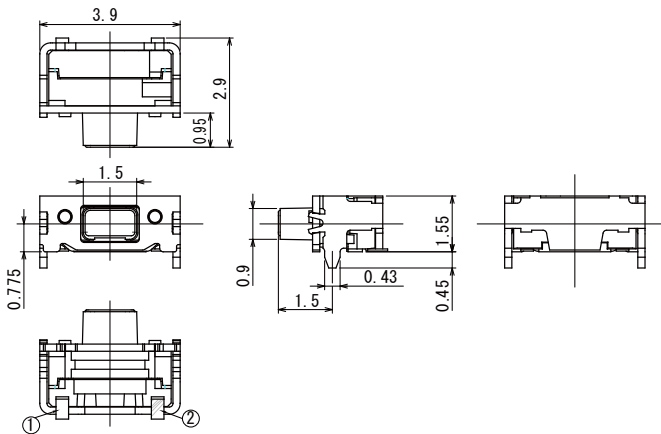

### PCB Mounting Dimensions

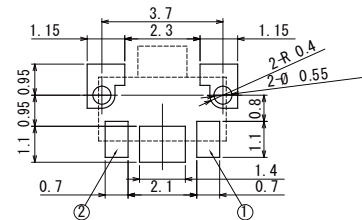

### Circuit Diagram

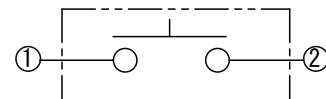

### Precautions when handling our products

1. For the export of products which are controlled items subject to foreign and domestic export laws and regulations, you must obtain approval and/or follow the formalities of such laws and regulations.
2. Products must not be used for military and/or antisocial purposes such as terrorism, and shall not be supplied to any party intending to use the products for such purposes.
3. Unless provided for otherwise, the products have been designed and manufactured for application in equipment and devices which are sold to end users in the market, including audio-visual (AV) equipment, electrical home appliances, office machines, information and communication equipment, and amusement equipment. The products are not intended for use in, and must not be used for, any application for nuclear equipment, driving equipment for aerospace or any other unauthorized use.  
With the exception of the abovementioned prohibited applications, please contact an Alps sales representative and/or evaluate the total system regarding applicability for applications involving high levels of safety and liability such as medical equipment, burglar alarm equipment, disaster prevention equipment and undersea equipment. Please also incorporate fail-safe design, protection and redundant circuitry, malfunction protection, and/or fire protection into the complete system to ensure safety and reliability of the total system.
4. Before using products which were not specifically designed for use in automotive applications, please contact an Alps sales representative.

### Cautions for using this catalog

1. The specifications herein are an overview of the specifications. Obtain official specifications before use.
2. The colors of the products in the catalog may slightly differ from those of the actual products.
3. The external appearance, functions and other specifications herein may be discontinued without prior notice.
4. All product names, company names and names of standards described in this catalog are trademarks or registered trademarks of their respective owners.
5. The contents of this catalog are according to Alps Electric as of May 2014.
6. This catalog is valid until December 31, 2014.

### Inquiries about this product

Product Information Center  
+81 (3) 5499-8154  
Product Information URL  
<http://www.alps.com/products/e/>

**ALPS ELECTRIC CO., LTD.**  
1-7, Yukigaya-otsukamachi, Ota-ku, Tokyo, 145-8501, Japan